

Introduction

Veljan Hydrair Limited has developed the expertise to design, manufacture and service highly engineered extra heavy duty Roll Force /AGC Cylinders and custom built special purpose hydraulic cylinders since 1970.

This is apart from the regular production of standard ISO 6020 & ISO 6022 series Hydraulic cylinders manufactured at Veljan.

Heavy duty Roll Force Cylinders find application in Automatic Gauge control systems (AGC) in Cold Rolling Mill Installations. These cylinders are designed and manufactured by Veljan, have been installed in United States of America, Canada, Europe, Africa, Bangladesh, Middle East and Vietnam.

Special purpose Hydraulic cylinders include cylinders manufactured for use in Stacker Reclaimers, Rail Wagon Tipplers, Material handling equipments, Steel Rolling Mill equipment, Steel Melting furnaces for tilting & electrode positioning applications, where operational accuracy & safety are of prime importance.

The key feature of these hydraulic cylinders is that each cylinder is custom built to the specific need of the each customer. Materials and alloys for the construction are carefully chosen depending upon the application, intensity of usage, operating pressure, speeds and temperature.

In large bore cylinders, the outer body is manufactured out of single piece forging without any weld joints. The piston rod and piston are made from a single piece forging. All other components are also manufactured from single piece forgings.

The forged materials are checked for grain size, microstructure, metallurgical compositions and mechanical properties. All forgings are proof machined, normalized and subjected to Ultrasonic tests as per ASTM SAE 388 standards for any flaws in material and internal defects.

The manufactured hydraulic cylinders are subjected to cyclical test and proof pressure test as per IS 10585 : 2012 or as per customer specific test standards.

Salient Design Features of Veljan Roll Force Cylinders:

- Designed for continuous operation of 24/7 basis
- Design factor of safety > 2.5 at Proof Pressure
- Forged and Normalized Steel Body and Piston Rod for long life.
- Low Friction High Speed PTFE Bronze Dual pack Sealing System for redundancy in operation
- Expected life of cylinder 15 – 20 years on 24 / 7 basis
- Expected life of seals 4-6 years on 24 / 7 basis.
- Leak proof under severe duress under working conditions
- Operating Pressure up to 350 bar
- Maximum loads exceeding 2000 Tons per cylinder
- Continuous load holding capability.
- Operating temperatures Standard : 0- 80° C (0-180° C on request)
- Hard Chrome plated corrosion resistant Piston Rod.

TYPICAL SELECTION CHART for Roll Force and Long Stroke Hydraulic Cylinders.

Boreø (mm)	Piston Rod ø (mm)	Stroke(mm) Maximum	Hydraulic Cylinder Load (Tons)			Construction Forged/ Tubular
			at 200 Bar	at 250Bar	at 300 Bar	
280	140 / 200	7500	120	150	180	Forged Steel / Tubular steel construction is offered for strokes up to 2500mm and Tubular Steel construction for higher strokes up to 7500mm
300	140 / 200	7500	140	175	210	
320	180 / 220	7500	160	200	240	
350	220 / 250	7500	190	240	285	
380	250 / 320	7500	225	280	340	
400	320 / 350	7500	250	310	375	
420	350 / 380	7500	275	345	415	
450	380 / 420	7500	315	395	475	
480	420 / 450	5000	360	450	540	
500	420 / 450	5000	390	490	585	
520	450 / 480	2000	420	530	635	Forged steel
550	450 / 480	2000	430	535	645	
580	480 / 520	2000	525	660	790	
600	520 / 550	2000	565	705	845	
620	550 / 580	1000	600	750	905	
650	550 / 580	1000	660	825	995	
680	580 / 620	1000	725	905	1085	
700	620 / 650	1000	765	760	1150	
720	650 / 680	1000	810	1015	1221	
750	680 / 720	1000	880	1100	1325	
780	720 / 780	1000	955	1190	1430	
800	720 / 750	1000	1000	1255	1505	
820	750 / 780	1000	1055	1320	1580	
850	780 / 820	1000	1130	1415	1700	
880	820 / 850	1000	1215	1520	1820	
900	820 / 850	1000	1270	1590	1905	
920	850 / 880	1000	1325	1660	1990	
950	880 / 920	1000	1415	1770	2125	

Note:

1. Working Pressure limited to 250 bar in case of Tubular construction. HFS Seamless tubes from reputed sources will be used for tubular construction. Hydraulic Cylinders for higher working pressure up to 350 bar are offered with forged steel construction.
2. Veljan hydraulic cylinders for bore sizes 100mm to 250mm are of Cold Drawn Seamless tube construction. Strokes lengths up to 7500 mm can be offered in these bore range.
3. Apart from the bore and piston rod dimensions indicated in the chart additional / intermediate bore and piston rod sizes can be manufactured upon specific requirement of projects.

Mounting Options For Heavy Duty Hydraulic Cylinders

1. Encapsulated in Mill Housing with close tolerance between outer body dimensions of the hydraulic cylinder and the housing.

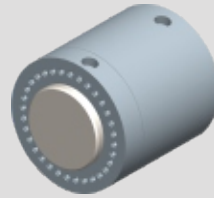

2. Front / Rear Flange Mounting for Hydraulic Press applications.

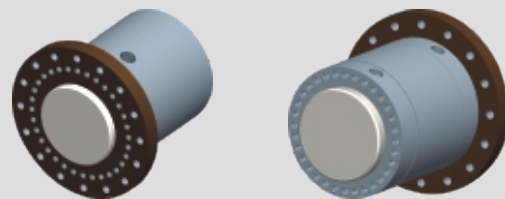

3. Rear Clevis Mounting with Spherical Bearings.

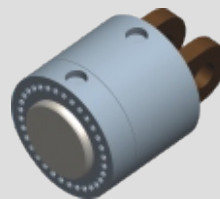

4. Intermediate Trunion Mounting - Trunion on cylinder body.

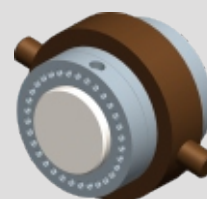

5. front end / Rear end Trunion Mounting

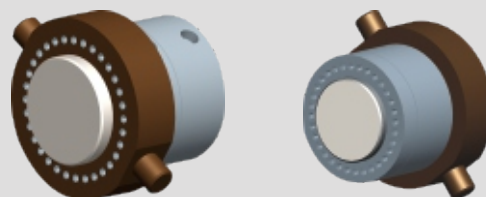

Standard SAE Port Option For Hydraulic Cylinders Maximum Working Pressure 400bar (6000 Psi)

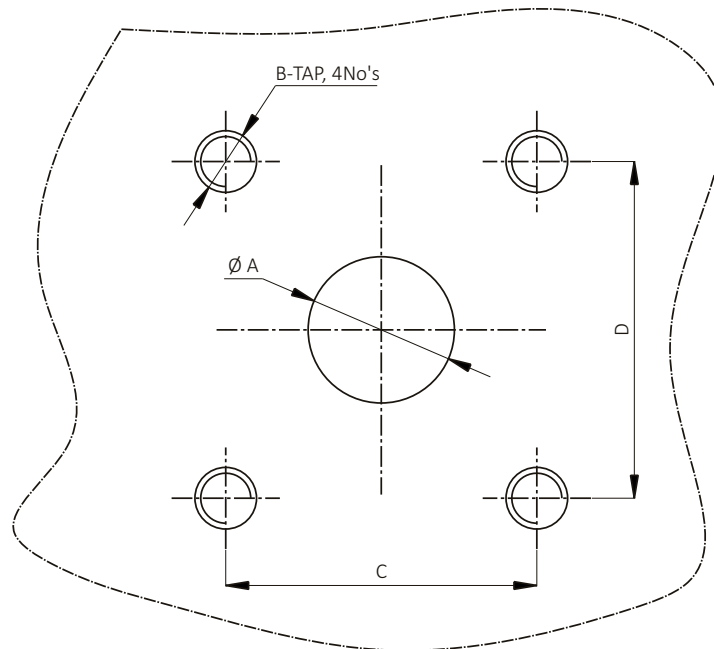

S.No.	Ø A(Inch)	Ø A(mm)	B (Thread B X Depth)	C(mm) ±0.25	D(mm) ±0.25
1.	1/2"	12.7	M8 X 15	18.25	40.29
2.	3/4"	19.05	M10 X 18	23.80	50.80
3.	1"	25.4	M12 X 20	27.76	57.15
4.	1-1/4"	31.75	M14 X 25	31.75	66.68
5.	1-1/2"	38.1	M16 X 30	36.50	79.38
6.	2"	50.8	M20 X 35	44.45	96.82
7.	2-1/2"	63.5	M22 X 40	58.73	123.83
8.	3"	76.2	M27 X 50	71.43	152.40

Roll Force Cylinders / AGC Cylinders for Cold Rolling Mills:

Roll Force Cylinders are specially built Hydraulic Cylinders which are used in Cold Rolling Mills in Steel Industries. Typically these Cylinders are encapsulated in the Mill Housing. These Cylinders are used in pairs to hold the Work roles in position under pressure during the rolling operation. These are typically short stroke, hydraulic cylinders; where in the load exerted by each cylinder is up to 1500 Tons. All the components of these cylinders are manufactured by using specially forged steel alloys. Precision machining is done to achieve close tolerance & fits on mating components to avoid leakage of oil at high pressures. Low friction PTFE Bronze seals are used for smooth operation and long life. Linear position transducer can be fitted externally or inside the main piston rod assembly as per the design of the mill.

Typical Schematic Look of Roll Force Cylinders:

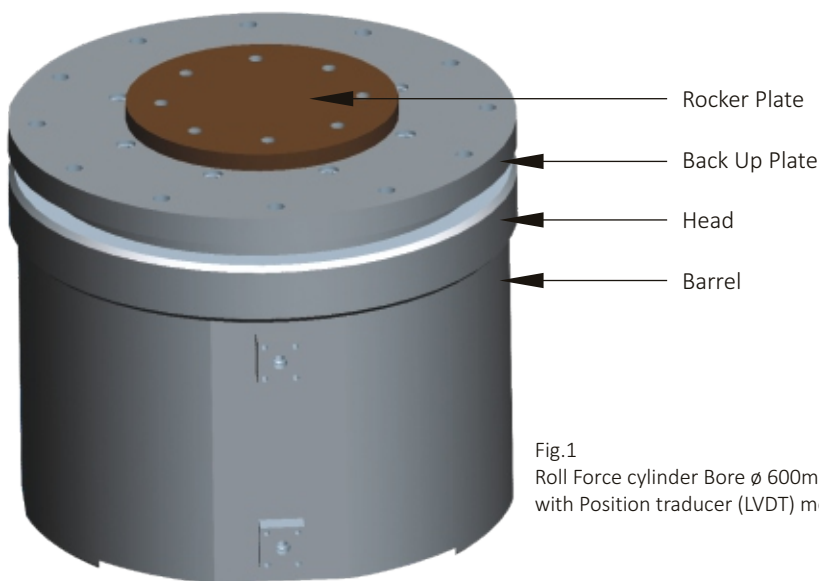

Fig.1
Roll Force cylinder Bore ϕ 600mm x Piston Rod ϕ 550mm x Stroke 180 mm
with Position traducer (LVDT) mounted inside the Cylinder.

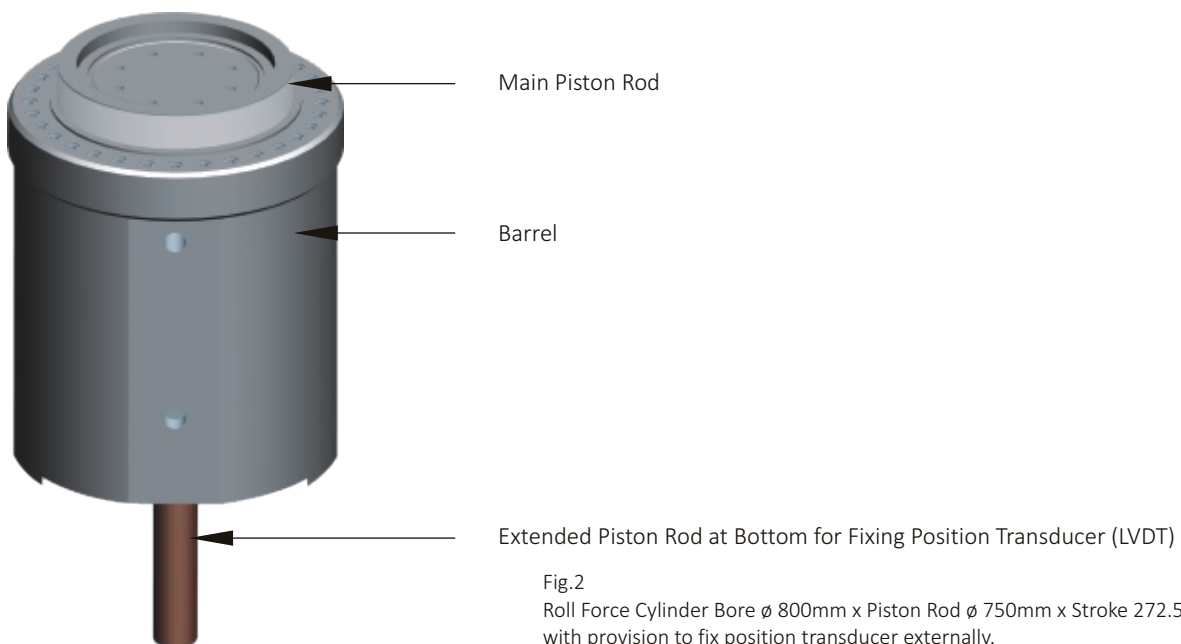

Fig.2
Roll Force Cylinder Bore ϕ 800mm x Piston Rod ϕ 750mm x Stroke 272.5 mm
with provision to fix position transducer externally.

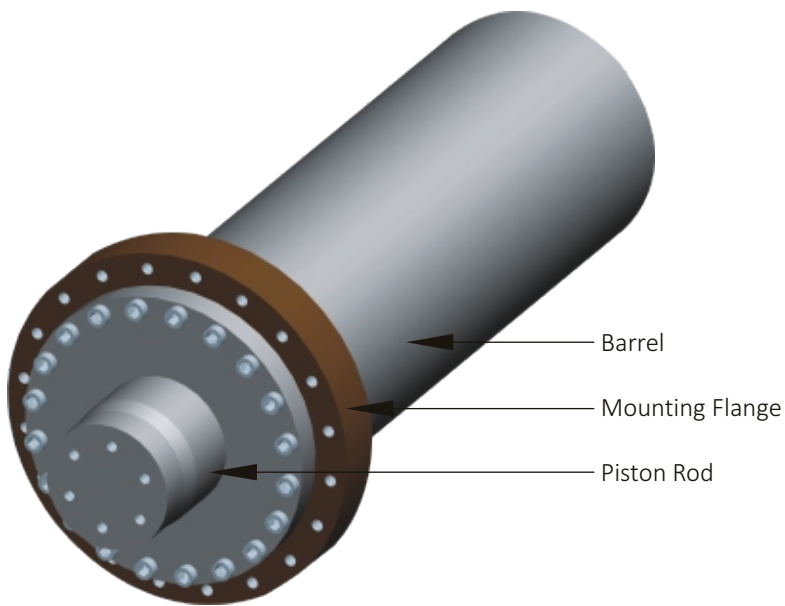

Fig.3
Heavy Duty Hydraulic Cylinder Bore ϕ 450mm x Piston Rod ϕ 300mm x Stroke 1250 mm.
Working pressure at 300 bar & Test pressure 450 bar.

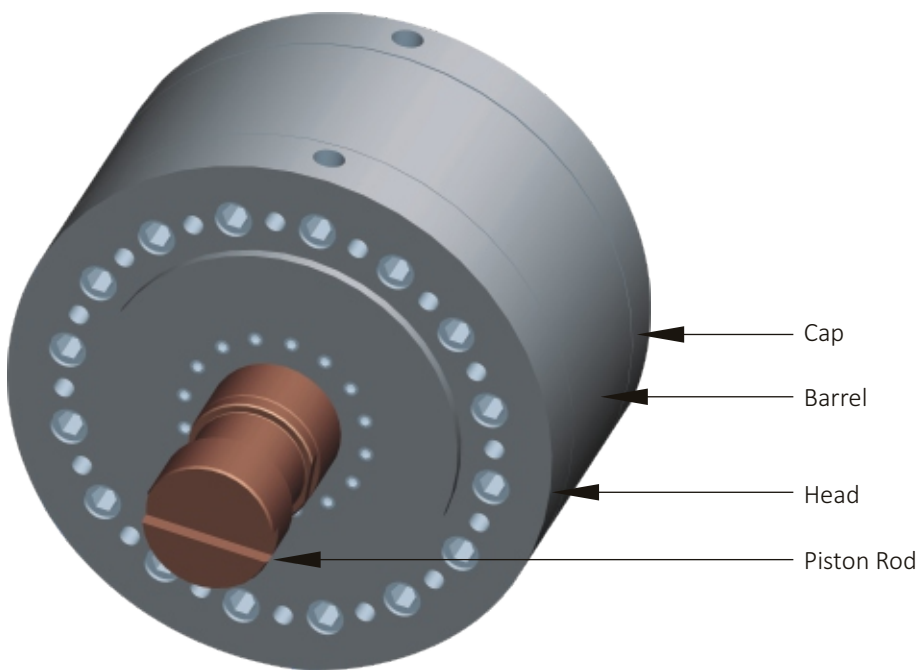

Fig.4
Hydraulic Rotary Cylinder Bore ϕ 600mm x Piston Rod ϕ 560mm x Stroke 65mm.



1. Typical View of a Roll Force Cylinder Bore \varnothing 800mm x Piston Rod \varnothing 750mm x Stroke 272.5mm
Fully assembled with Pressure pad (Mounting Type 1 Encapsulated in Mill Housing)

Technical Data Sheet for Roll Force Cylinders & Heavy Duty Press Cylinders

S.No.	Description	Operating Pressure (bar)	Test Pressure (bar)	Specifications/ Materials of Construction
1.	Hydraulic Cylinder Mounting Options (Ref Table II)	250 - 350	375 - 450	1. Encapsulated in Mill Housing with close tolerance between outer body dimensions of the hydraulic cylinder and the housing.
				2. Front / Rear Flange Mounting for Hydraulic Press applications.
				3. Rear Clevis Mounting with Spherical / Thrust bearings.
				4. Intermediate Trunion Mounting - Trunion on cylinder body.
				5. Front end/ Rear end Trunion Mounting
2.	Cylinder Body / Barrel for normal conditions	250	375	Forged Carbon Steel alloys
		300	450	Forged Steel alloys
		350	450	Forged Steel alloys
3.	Cylinder Body / Barrel for corrosive environments	250 - 350	375 - 450	Forged SS304 / SS316
4.	Piston and Piston Rod for normal operating conditions	250	375	Forged Carbon Steel alloys
		300	450	Forged Steel alloys
		350	450	Forged Steel alloys
5.	Piston and Piston Rod for chemical and corrosive operating conditions	250 - 350	375 - 450	Forged SS304 / SS316
6.	Ultrasonic Test Std for Forgings	250 - 350	375 - 450	ASTM A 388 with straight beam examination

Technical Data Sheet for Roll Force Cylinders & Heavy Duty Press Cylinders

S.No.	Description	Operating Pressure (bar)	Test Pressure (bar)	Specifications/ Materials of Construction
7.	Design Factor of Safety for Barrel	250		4.0 (minimum)
			375	2.5 (minimum)
8.	Design Factor of Safety for Piston Rod	250		> 12
			375	> 10
9.	Surface Finish in Barrel (Ra)			<0.40µm
10.	Surface Finish on Piston Rod (Ra)			<0.40µm
11.	Piston Rod Hard Chrome Plating			60 µm on ϕ / 30µm per side
12.	Piston Seal	250 - 350	375 - 450	Low Friction High Speed Seals from European / US Origin. NBR /PU/PTFE Bronze/PTFE Glass for 0-80°C (VITON PTFE/Bronze for 0 - 180°C applications/alternate seals on request)
13.	Rod Seals	250 - 350	375 - 450	Low Friction High Speed Seals from European /US origin. NBR /PU/PTFE Bronze/PTFE Glass for 0-80°C (VITON PTFE/Bronze for 0 - 180°C applications/alternate seals on request)
14.	High Tensile Fasteners	250 - 350	375 - 450	Grades: 10.9 for Hex Head/ 12.9 for Socket Head fasteners. SS Fasteners upon request

Technical Data Sheet for Roll Force Cylinders & Heavy Duty Press Cylinders

S.No.	Description	Operating Pressure (bar)	Test Pressure (bar)	Specifications/ Materials of Construction
15.	Bearings (Optional / Case specific)			SKF/ELGES/IKO/LS
16.	Operating Temperature (Normal)			0 - 80° C (Cylinder with NBR/PU/PTFE Seals)
17.	High Temperature application (on request)			0 - 180° C (Cylinder with VITON/PTFE Seals)
18.	LVDT (Linear Variable Displacement Position Transducers, Analogue / Digital)			Optional external / internal upon specific request.
19.	Embedded Proximity Switch			Optional upon specific request.
20.	Bellows (Optional / case specific)			Leather / Synthetic depending upon application
21.	Mounting dimensions and Port sizes			1"-2"BSP/ ISO 6162 Table III (400 bar) (SAE 6000PSI)
22.	Static Friction (Breakaway Pressure)			< 5 Bar
23.	Working Pressure Range			0-350 Bar
24.	Test Pressure Range			1.5 x Working Pressure.
25.	Testing Fluid	250 - 350	375 - 450	ISO VG 68
26.	Operating Fluid Range	250 - 350	375 - 450	ISO VG32/ISO VG 46 / ISO Vg68/ Quintolubric 888 / Water Glycol (Optional to end user)
27.	Testing Standard			IS 10585 :2012
28.	Corrosion Protection Class			CRC III / CRC IV (Optional)

Technical Data Sheet for Roll Force Cylinders & Heavy Duty Press Cylinders

S.No.	Description	Operating Pressure (bar)	Test Pressure (bar)	Specifications/ Materials of Construction
29.	GA Drawing			Case Specific G.A. Drawing will be offered to customer for approval upon receipt of Purchase Order
30.	Identification and Traceability			Name Plate and Markings: All Hydraulic Cylinders will be fixed with Veljan Name Plate mentioning the Cylinder size, Order Acceptance Number, Drawing No, Month and Year of Manufacture, Operating Pressure and Test Pressure for identification and traceability.
31.	Painting			As per standard first coat with SKPS Gray, Final coat with Silver Ash Hammer Tone finish to achieve 100 μ m DFT.
32.	Packing			Moisture proof inner layer Polythene sheet packing & Wooden Box for external protection. Export packing wherever required.

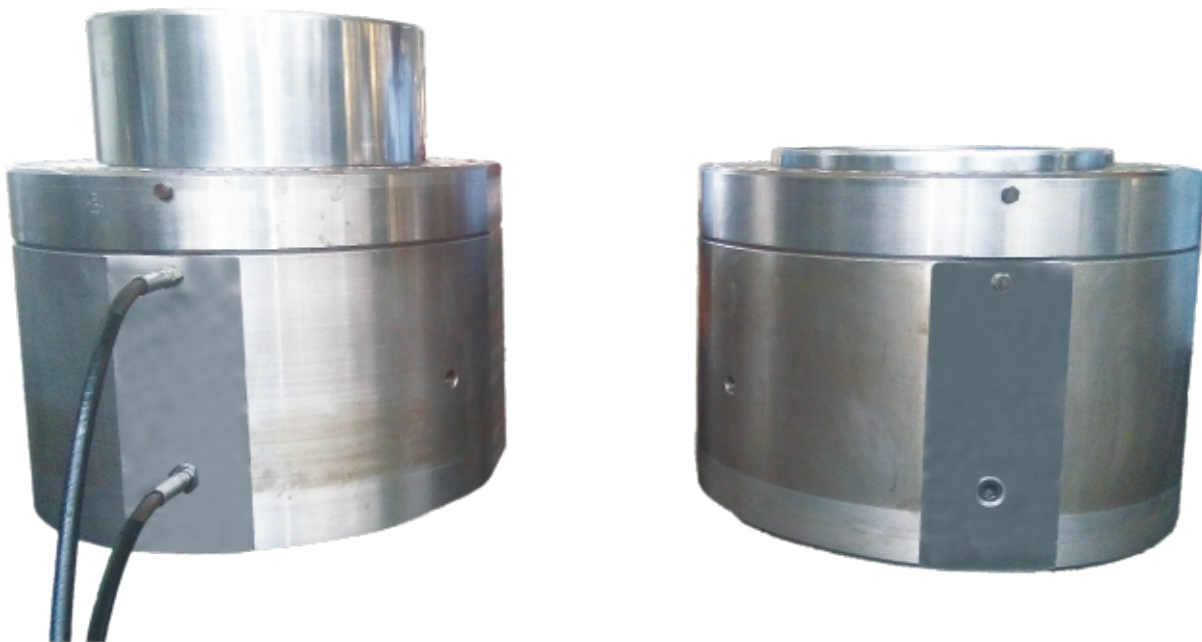

2. Typical View of a Roll Force Cylinders Bore ϕ 800mm x Piston Rod ϕ 750mm x Stroke 272.5mm under cyclical operation test.



3. Typical View of a Roll Force Cylinders Bore ϕ 800mm x
Piston Rod ϕ 750mm x Stroke 272.5mm
--Fixing of Pressure Pad (Rocker Plate)

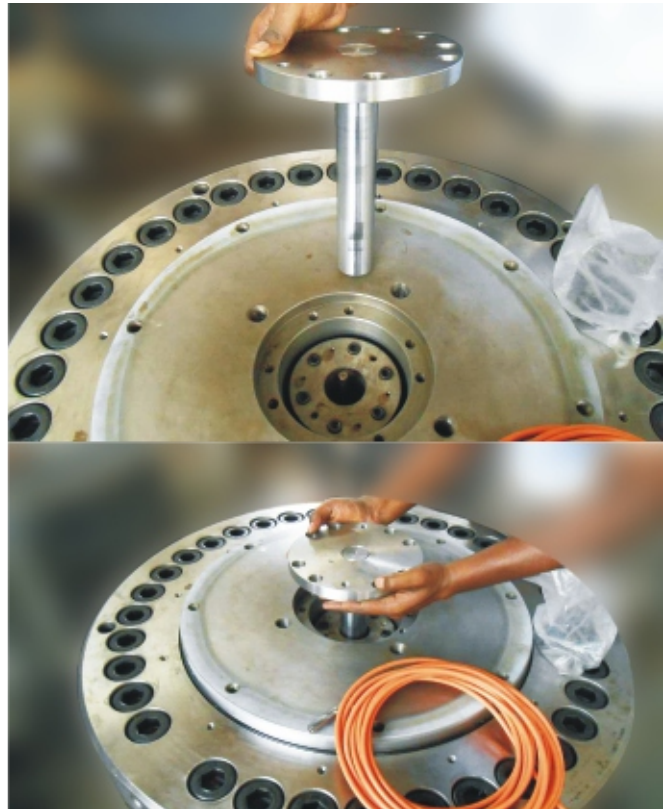

4, 5. Typical Views of fixing internal position transducers
(LVDT) in ϕ 600mm Roll Force Cylinders



6, 7. Typical Views of Pressure testing facility for Roll Force Cylinders and Heavy duty Press Cylinders.

Hydraulic Cylinders for Stacker Reclaimers:

Veljan has specially designed and manufactured hydraulic systems & cylinders for stacker reclaimer applications for NTPC, Private & Government Power Plants. The entire hydraulics package for these projects has been sourced from Veljan group companies by reputed manufacturers in this segment.

The hydraulic cylinders for Stacker reclaims are either manufactured out of forged construction or tubular construction depending upon the stroke lengths & Bore diameters.

These Cylinders supplied by Veljan are in operation at various power plants, steel mills and sea ports. Each cylinder is manufactured and designed to the specific requirements of the customer. The design considerations involve atmospheric severity, minimum factor of safety of 2.5 under load, speed & frequency of operation on 24/7 usage. All the components used for manufacturing such cylinders are chosen with extreme care for longer life expectancy and smooth operations.



Fig.5 Veljan 360mm ϕ x 200mm Piston Rod x 1500mm Stroke Hydraulic Cylinder for use in Stacker Reclaimers

Hydraulic Cylinders for long stroke applications:

Veljan long Stroke Cylinders find many applications in steel mills, material handling equipments and Dam gates. Veljan can design, manufacture and supply such long Stroke Cylinders from 100mm bore diameter to 500 mm bore diameter for a stroke length of 7500 mm. Seals selection will be based on working pressure speed, load and operating temperatures. Refer Typical Selection Chart for Roll Force and Long Stroke Hydraulic Cylinders on page 2, for details of bore diameters, Piston rod diameters, Stroke length, Cylinder load capability and nature of construction. Different Mounting options are indicated on page 3. Cylinders will be custom designed and manufactured to any specific application based on the requirements in operation and environmental conditions.

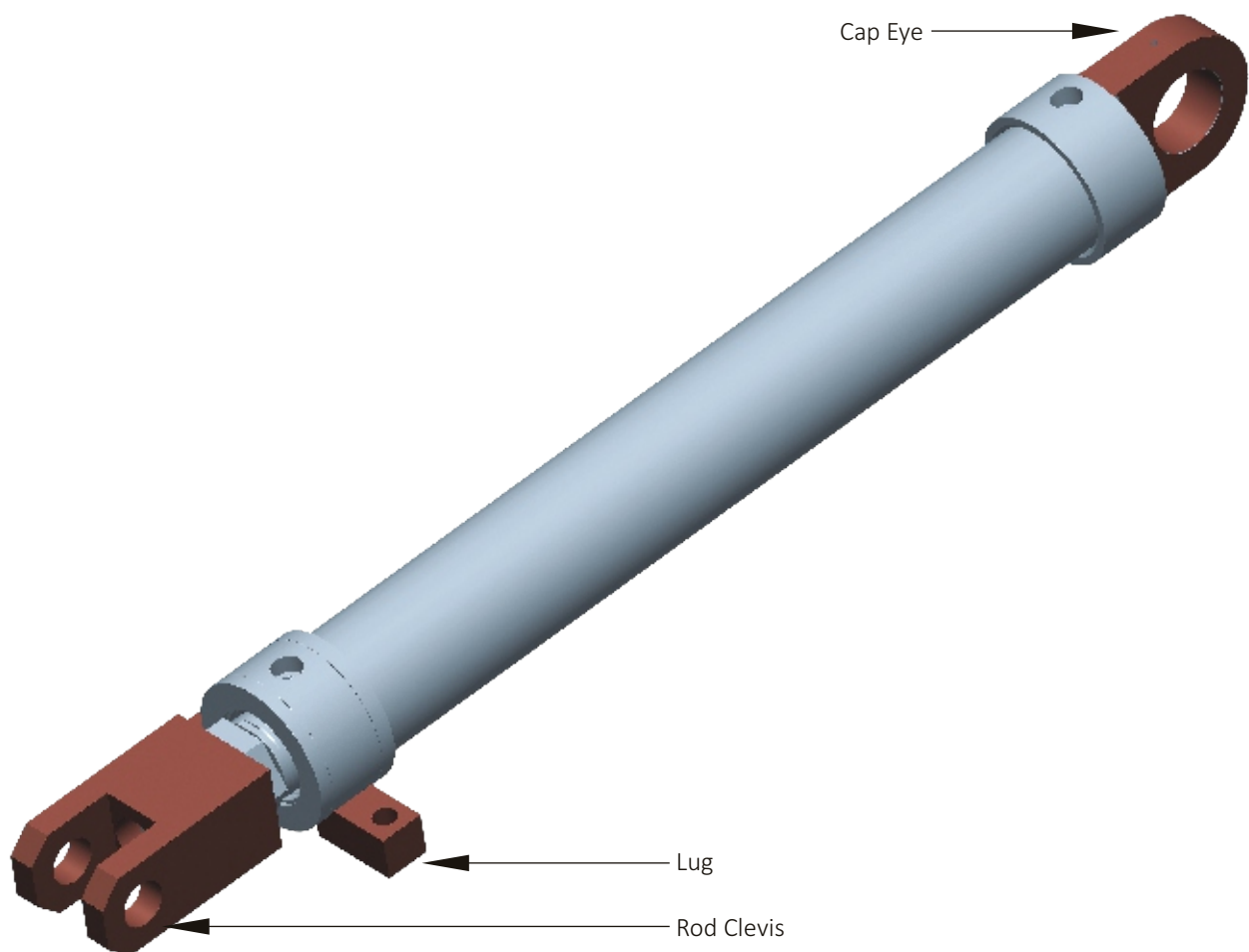

Fig.6 Foot and Clevis mounted Hydraulic cylinder Bore ϕ 250mm x Piston Rod ϕ 180mm x Stroke 6250 mm manufactured for several steel mills in India and abroad for Roll change application.



8. Typical View of packing of bore 360mm \varnothing x 200mm Piston Rod x 1500mm Stroke Stacker Reclaimer Hydraulic Cylinders (Operating Pressure 250 Bar Test Pressure 375 bar)



9. Cyclical Testing of Bore 360mm \varnothing x 200mm Piston Rod x 1400mm Stroke Hydraulic cylinder for Thermal Power Plant applications. (Operating pressure 250 bar, Test Pressure 375 bar)



10. Typical View of Veljan Long Stroke Cylinder: Bore 320mm \varnothing x 200mm Piston Rod x 5500mm Stroke
(Operating Pressure 250 bar, Test Pressure 375 bar)



1. Packed hydraulic cylinder for export.